

— Assembly and Safe Use Manual —



Customer Service
(800) 247-7668

4 TIER INDOOR BLEACHER

Models BLI0704, BLI1504

PARTS LIST							
Item	7-1/2' Qty	15' Qty	Description	Item	7-1/2' Qty	15' Qty	Description
A	7	14	7 1/2' Plank	K	2	3	Spacer
B	2	3	Welded Frame	L	28	42	3/8" x 1" Carriage Bolt
C	17	26	3/8" x 1 1/4" Hex Bolt	M	28	28	#10 x 3/4" Sheet Metal Screw
D	10	15	3/8" Flat Washer	N	14	14	Seat End Cap
E	51	77	3/8" Hex Nut	O	2	3	3/8" x 2 1/4" Hex Bolt
F	51	77	3/8" Lock Washer	P	4	6	Swivel Caster
G	28	42	Bench Clamp	Q	0	14	Seat Connector Tube
H	10	15	Rubber Foot	R	0	7	Seat Connector Cap
I	1	2	Front Brace	S	0	56	#14 x 3/4" Self-Drilling Hex Screw
J	2	4	Rear Brace	T	0	1	3/8" Hex Magnetic Socket

NOTE: Extra hardware may be included

- ◆ Inspect all contents prior to installation. Report any missing parts to dealer immediately.
- ◆ Read all instructions before proceeding.

Warning !

While gym floor installers and refinishers often indicate floors are OK to walk or play on in 7-10 days after oil based polyurethane finishes are applied, in reality, it can actually take up to 30 days for all the chemicals in the polyurethane to dissipate. Chemical reactions between the floor finish and certain materials including urethane feet contacting the floor can cause permanent discoloration. Placement of this product on floors prior to the 30-day final cure period may risk discoloration that would not be covered by the manufacturer's warranty.

1. Attach *Rubber Feet* (H) in 4 places to each *Welded Frame* (B) using *3/8" x 1 1/4" Hex Bolts* (C), *3/8" Flat Washers* (D), *3/8" Lock Washers* (F) and *3/8" Hex Nuts* (E). See Figure 1.
2. Position *Welded Frames* (B) approximately 72" apart on a level flat surface. Install *Front Brace* (I) using *3/8" x 1 1/4" Hex Bolts* (C), *3/8" Lock Washers* (F) and *3/8" Hex Nuts* (E). See Figure 2.

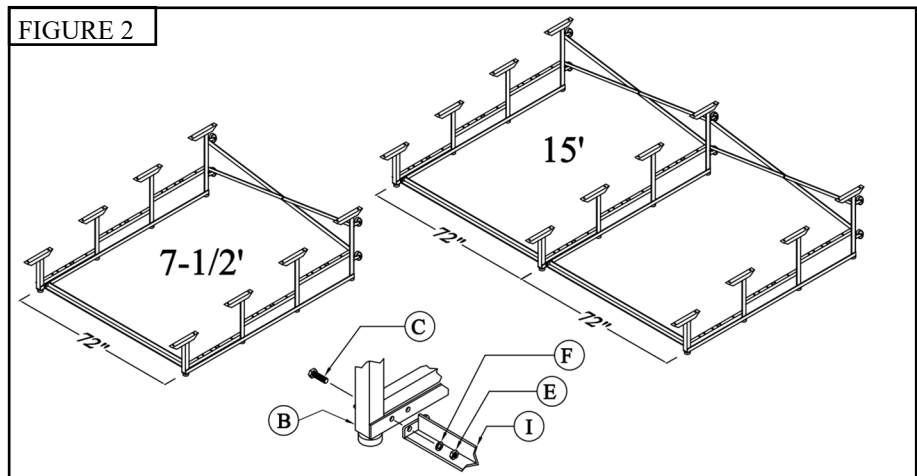
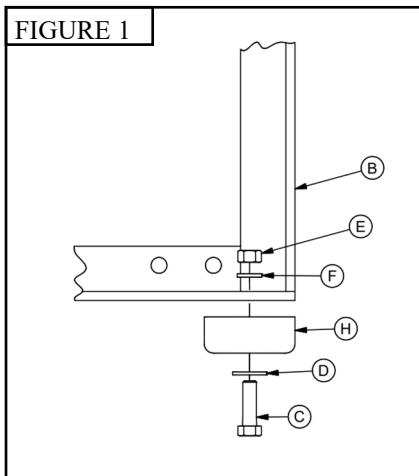

- 3 Using one each $3/8'' \times 1\ 1/4''$ Hex Bolt (C), $3/8''$ Lock Washer (F) and $3/8''$ Hex Nut (E) connect the two Rear Braces (J) in the middle, leaving hardware finger tight. See Figure 3.
- 4 Use $3/8'' \times 1\ 1/4''$ Hex Bolts (C), $3/8''$ Lock Washers (F) and $3/8''$ Hex Nuts (E) to attach the top of Rear Braces (J) in the fourth hole down from the top of the Welded Frames (B) and the bottom of the Rear Braces (J) into the fifth hole. See Figure 3.
- 5 Install Swivel Casters (P) into the first and sixth holes down from the top of Welded Frames (B) and attach with $3/8''$ Lock Washers (F) and $3/8''$ Hex Nuts (E). See Figure 3.
- 6 Attach Spacers (K) and Rubber Feet (H) through the bottom hole in the Welded Frames (B) with $3/8'' \times 2\ 1/4''$ Hex Bolt (O), $3/8''$ Flat Washer (D), $3/8''$ Lock Washer (F) and $3/8''$ Hex Nut (E). See Figure 3.
- 7 If your bleachers are 7 1/2' long, proceed to Instruction #14.

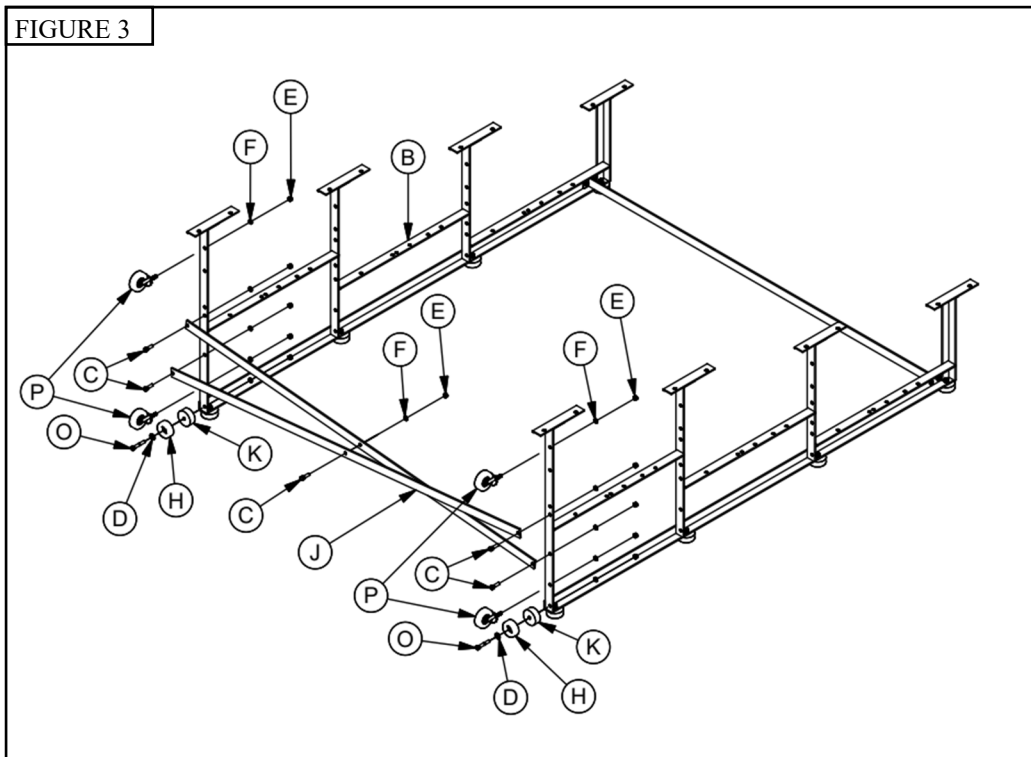

- 8 Please note that 15' bleachers will be assembled using two 7 1/2' Planks (A). Plank assembly will require a cordless or electric drill to install the #14 x 3/4" Self-Drilling Hex Screws (S) using the 3/8" Hex Magnetic Socket (T) included. Lay planks end to end on a flat surface with the bottom side of the planks facing up. See Figure 4.
- 9 Insert two Seat Connector Tubes (Q) approximately 5" into one end of a plank that will be connected to an adjacent plank. Using your drill, and the provided 3/8" Hex Magnetic Socket (T), install four #14 x 3/4" Self-Drilling Hex Screws (S) as shown in Figure 4.
- 10 Slide Seat Connector Cap (R) over the protruding Seat Connector Tubes (Q). See Figure 4.
- 11 Slide the second plank over the two Seat Connector Tubes (Q) making sure that it is tight against the Seat Connector Cap (R) and the first plank. See Figure 4
- 12 Install four additional #14 x 3/4" Self-Drilling Hex Screws (S) to complete the joint connection. See Figure 4.
- 13 Repeat process at each plank joint.

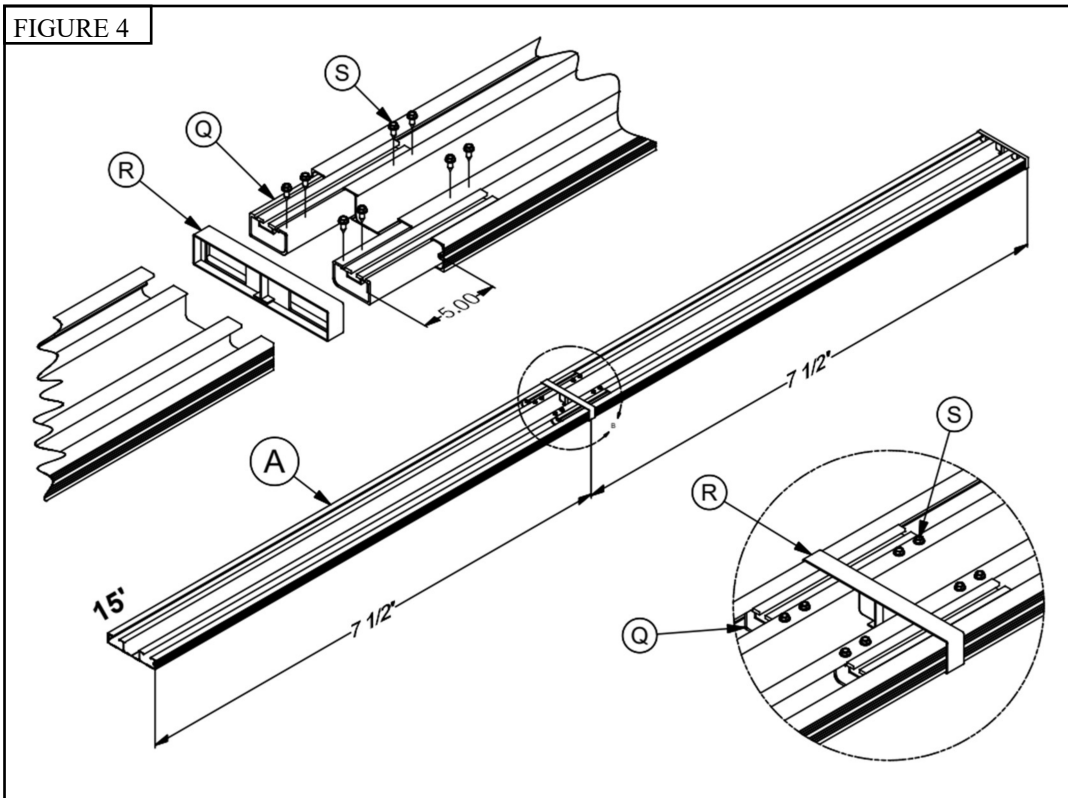

14. Attach 7 1/2' Planks (A) or plank assemblies with 3/8" x 1" Carriage Bolts (L), 3/8" Lock Washer (F), 3/8" Hex Nuts (E) and Bench Clamps (G). Use the mounting holes that are approximately 12" and 18 1/2" from the back of the Welded Frames (B) to attach Plank Assemblies. Each Plank Assembly should extend equal distance on both sides from outside Frame Assemblies. Make sure Welded Frames (B) are square and parallel to each other prior to tightening all hardware. See Figure 5.

NOTE: In locations where the connection points of the plank assemblies interfere with the attachments of the Weld Frame (B) do not use the Bench Clamp (G), as the 3/8" x 1" Carriage Bolt (L) square head will fit directly into the Seat Connector Tube (Q) slot. See Figure 6.

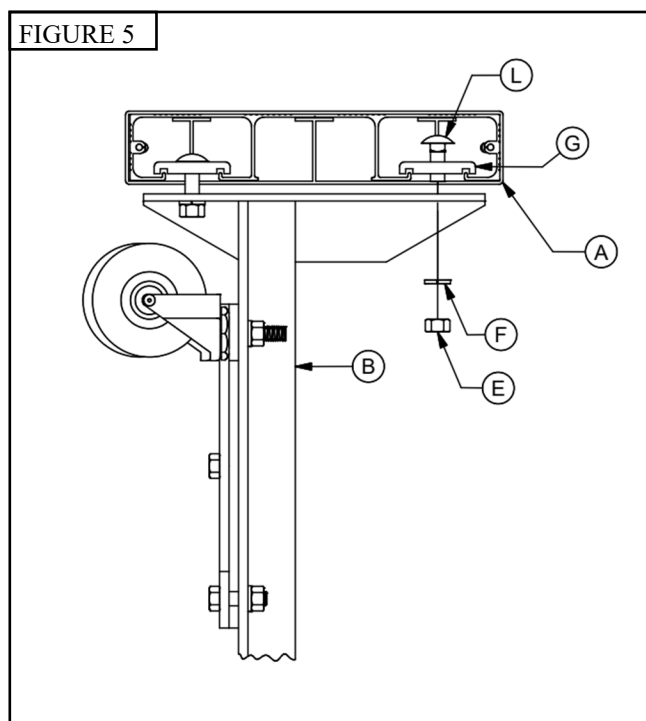

15. Install Seat End Caps (N) with #10 x 3/4" Sheet Metal Screws (M). See Figure 7.

16. Make sure all hardware is tightened prior to use.

